



Acoustek

Acoustek Australia

E: sales@acoustek.com.au

Ph: +61(0) 418 792 788

Web: www.acoustek.com.au

Acoustek New Zealand

E: sales@acoustek.co.nz

Ph: +64 (0)22 430 2214

Opus Acoustic® Blades

Vibrato Plus

Vibrato 'Plus' indicates an increased 50% of 'Class A' absorptive material within the surface area of this already excellent performing Acoustic Blade Suspension System.

All Acoustek lighting is available either hard or soft wired and complies with international standards.

Vibrato Plus Ceiling Hung Acoustic Blades

Vibrato 'Plus' indicates an increased 50% of 'Class A' absorptive material within the surface area of this already excellent performing Acoustic Blade Suspension System.

The addition of Baffles within the system, angled at strategic points plus the introduction of an extra 'A' blade provides an extra 6sqm of Class A absorptive material into the system. These additions enhance

both the system's absorptive performance and aesthetic appeal, providing a solution for more challenging situations.

Vibrato Plus now offers 18sqm of Class A absorptive material placed within a 5.6sqm surface area - a feat not matched by any other suspension system and a great 'Acoustician's Solution' for glass walled Boardrooms/Offices/Restaurants.

Performance example

NRC ratings above 0.90 will place a product into Class A sound absorption rating, Vibrato Plus has no competition with ability of NRC 0.95, convert to Biophilic Design to support Body, Mind and Soul via a touch of nature.

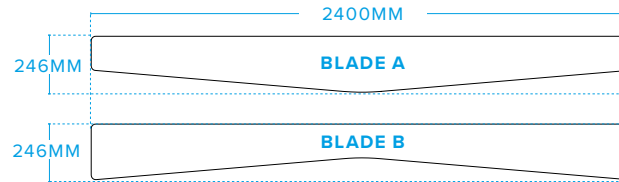

Frequency (Hz)	SAC	Oct
100	0.17	
125	0.20	0.23
160	0.31	
200	0.51	
250	0.70	0.65
315	0.75	
400	0.80	
500	0.83	0.84
630	0.88	
800	0.89	
1000	1.10	1.06
1250	1.18	
1600	1.27	
2000	1.35	1.34
2500	1.41	
3150	1.45	
4000	1.44	1.43
5000	1.40	
NRC	NRC 0.95	
Alpha	0.90	
SAC	A	

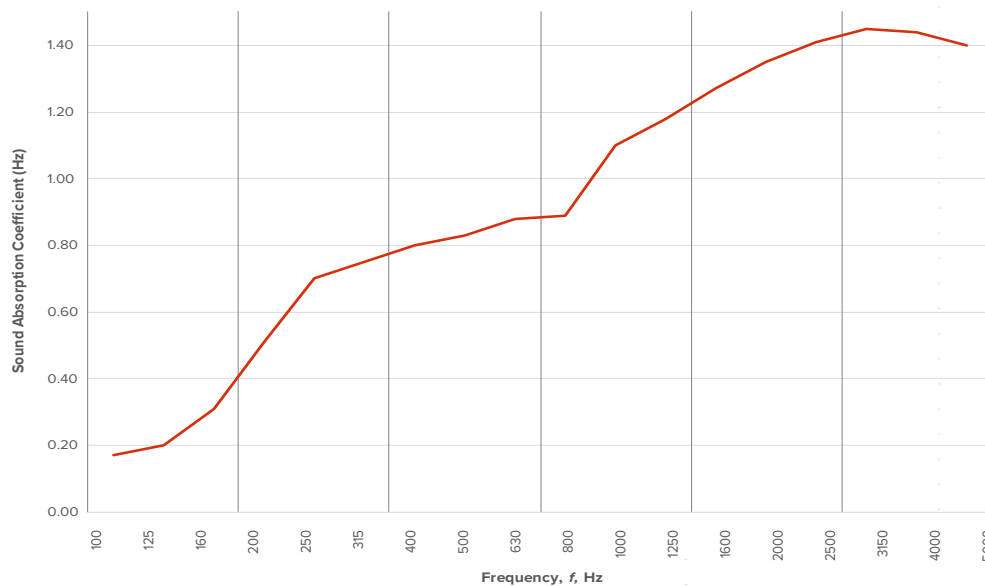

Adagio Ceiling Hung Acoustic Blades

Adagio has a more gentle flowing contour, aesthetic appeal is very subjective but this simple contour has individuality that will combine with any of the wall blades also as per our illustrated example the Diffuse Acoustic tiles complement the system perfectly aiding room noise attenuation.

Adagio blades are shaped from 150mm to 198mm - forming an easy contour, the blades are cut from proven acoustic material with minimum NRC 0.65, this being calculated on single side of the sheet being exposed. We cut the sheet and position as blades, thereby increasing the surface area - every surface of the board is now exposed.

Depending upon blade spacings we can achieve up to NRC 0.90 - absorb up to 90% of reverberate noise.

ADAGIO

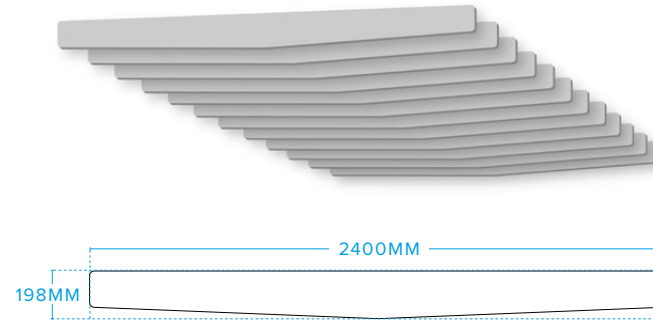

Vibrato and Medley Acoustic Blades

The alternating Vibrato blade shapes suspended from the ceiling provide extra design flair, this design has more complexity and interest, a great feature for any boardroom.

Vibrato has 2 opposing angled blades cut from proven acoustic material with minimum NRC 0.65, this being calculated on single side of the sheet being exposed. We cut the sheet and position as blades, thereby increasing the surface area - every surface of the board is now exposed.

Depending upon blade spacings we can achieve up to NRC 0.90 - absorb up to 90% of reverberate noise.

Medley vertical blades alternate from 80mm to 120mm depth.

VIBRATO

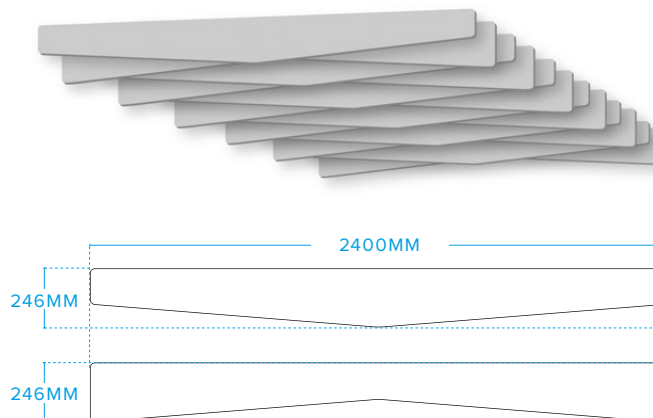

Sonata Major & Sonata Minor Acoustic Blades

Ceiling hung & Wall hung. The design change of a 45 degree angle terminating the end of each blade gives more individuality, the acoustic performance remains constant. The junction of ceiling and wall blades attempts a mitre giving detailed difference for the discerning.

Sonata blades are parallel cut with the addition of a 45deg angle to finish the blade ends, we use proven acoustic material with minimum NRC 0.65, this being calculated on single side of the sheet being exposed.

We cut the sheet into blades, thereby increasing the surface area - every surface of the board is now exposed. Depending upon blade spacings we can achieve up to NRC 0.90 - absorb up to 90% of reverberate noise.

SONATA MAJOR & MINOR

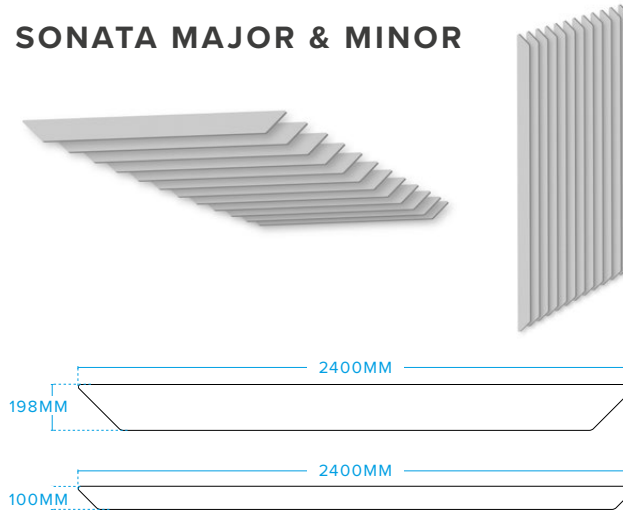

Tempo Major & Tempo Minor Acoustic Blades

Ceiling hung & wall hung. Whilst a basic blade design this product will enhance any room whilst curing it's reverberate noise issues, choose a colour or lighting to also enhance any decor.

Tempo blades are parallel cut from proven acoustic material with minimum NRC 0.65, this being calculated on single side of the sheet being exposed.

We cut the sheet into blades, thereby increasing the surface area - every surface of the board is now exposed.

Depending upon blade spacings we can achieve up to NRC 0.90 - absorb up to 90% of reverberate noise.

TEMPO MAJOR & MINOR

